

Date: \_\_\_\_\_

Customer: \_\_\_\_\_

Model #: \_\_\_\_\_

Serial #: \_\_\_\_\_



10"	<input type="checkbox"/>	<b>MRB's</b>	yes	<input type="checkbox"/>
12"	<input type="checkbox"/>		no	<input type="checkbox"/>
Single Shoot	<input type="checkbox"/>	<b>Row Cropping Option</b>	yes	<input type="checkbox"/>
Double Shoot	<input type="checkbox"/>		no	<input type="checkbox"/>
				(valving to retract every second opener for 20" & 24" spacing)
N/A	<input type="checkbox"/>	<b>Rear Drop Hitch</b>	yes	<input type="checkbox"/>
S/S Single Run	<input type="checkbox"/>		no	<input type="checkbox"/>
S/S Full Run	<input type="checkbox"/>			
D/S Single Run	<input type="checkbox"/>			
D/S Full Run	<input type="checkbox"/>			
N/A	<input type="checkbox"/>			
Installed	<input type="checkbox"/>			

**Tools required:**

- 1/2" drive torque wrench
- 5/16" nut driver
- 9/16" socket
- 7/8" socket
- 15/16" socket

# HYDRAULICS

*check*

Identification tags have been attached to couplers	
Cylinders are in correct location (CHECK CYLINDER LOCATION TABLE BELOW)	
Steel hyd lines are not bent or kinked	
All plastic line hold downs are tight and fastened with a lock nut	
Ensure that wire ties attaching Case Drain Line to others does not pinch off oil flow	
Ensure hoses to each PHD and MRB cylinder are well fastened to the frame, no hoses falling down that may get pinched by opener.	
If equipped with row crop lockout, ensure every second opener stays up when lockout valve is engaged. <b>See figure 1</b>	
Test control box to test raise/lower and pressure functions	

## Cylinder Locations

Wing Cyl	40		48		55
Right I.W.	3300-87		3300-87		3300-99
Right O.W.	N/A		3300-49		3300-53
Left I.W.	3300-87		3300-87		3300-99
Left O.W.	N/A		3300-49		3300-53

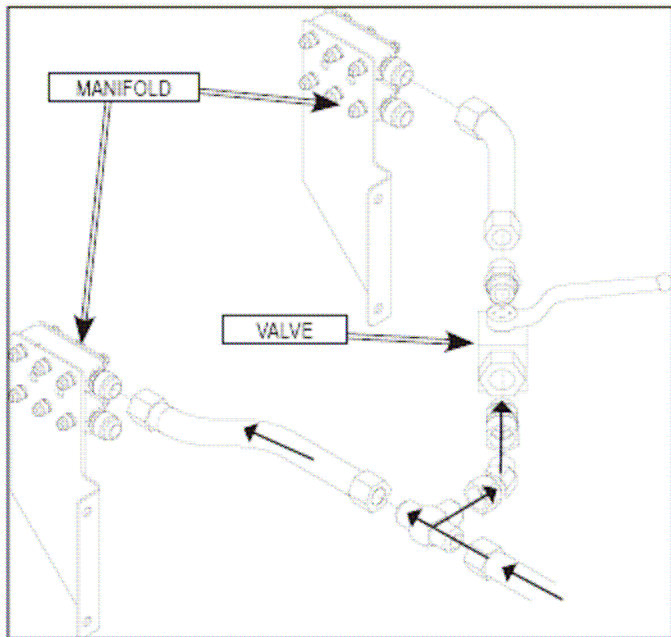

**Figure 1**

Suggested Completion Time = 15 min.

Signature: \_\_\_\_\_

Actual Time \_\_\_\_\_

# Section 1 Opener Assemblies

	<b>CHECK</b>
All packer wheels installed and Secured with 3/8" bolt and nylock	
Wheel bolts torqued to 65 ft-lb (+20 / -0 ft-lb)	
Verify tires( <b>random 5</b> ) for psi specification, 14 psi - 20 psi. (17 ± 3 psi)	
BTT openers (if installed) are secured and in line with shank	
Default depth setting on each opener at Hole Number 8	

## On Unit Checks

U-bolts are tightened evenly	
Castings are not chipped or have light paint	
All trips are in proper locations. +/- 1/4" ( <b>Check 5</b> )	
All bolts are tight	
The torque for the 5/8" cast mount bolts ( <b>130 ± 20 ft.lbs</b> ) have been verified for <b>5</b> trips (indicate on drawing) <b>15/16 socket</b>	

## Safety Lights

All Safety Lights work	
Safety Lights are Secure	
Amber lights are seated properly in holders	

Suggested Completion Time = 20min.

Signature: \_\_\_\_\_

Actual Time \_\_\_\_\_

# Opener Calibration

Check

Perform this calibration on 4 random openers.	
---	--

## 6.3.6 OPENER CALIBRATION

If repairs were performed on the opener it may need to be re-calibrated to ensure proper seeding depth. Re-calibration may also be required if the adjustment bolts have become loose. Follow the procedure below and refer to *Figure 6.24* to properly calibrate the opener.

1. Move the drill onto level ground.
2. Ensure the opener being calibrated is set to depth setting hole #8.
3. Lower the openers all the way to the ground. Slightly lift the openers to remove any pressure in the opener cylinders. The openers should move by hand now. If this is difficult, detach one end of the opener cylinder from the assembly.
4. Place a 12" block under the opener arm. The block should be the only support for the arm to take up any "slack" in the assembly. It is very important that only a 12" block is used, the ratio of both measurements is not linear.
5. Measure the distance from the center of the shank pivot pin to the ground. The acceptable measurement is 25 1/2" when set in hole #8.
6. If the measurement is out of spec, loosen the adjustment bolts to adjust the height of the spindle mount. Tighten the mounting bolts and measure again, re-adjust if necessary.

### WARNING

TO PREVENT SERIOUS INJURY OR DEATH, DO NOT GO UNDER THE MACHINE WHILE AN OPERATOR IS IN THE TRACTOR. PLACE STANDS OR BLOCKS UNDER THE FRAME BEFORE WORKING BENEATH THE MACHINE OR WHEN CHANGING TIRES. USE ONLY TOOLS, JACKS AND HOISTS OF SUFFICIENT CAPACITY FOR THE JOB.

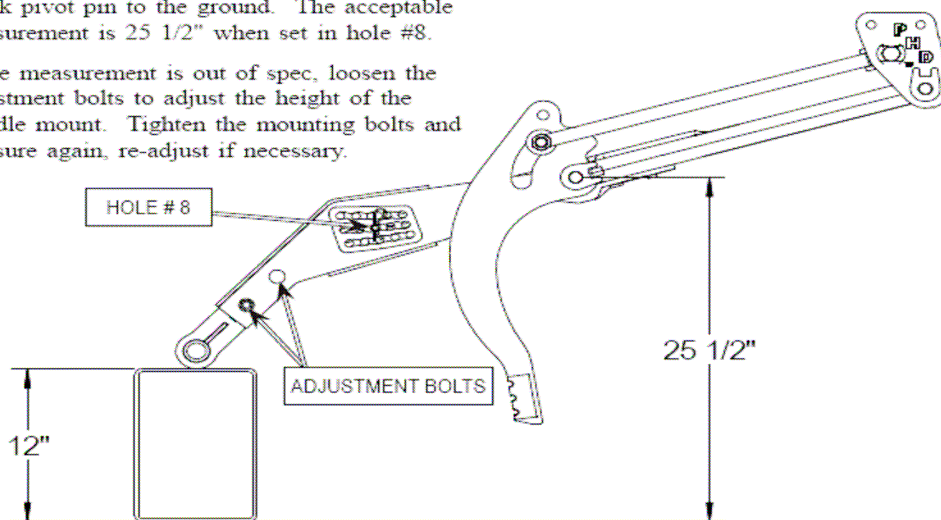

Figure 6.24 - Opener Calibration

63066\_CALIBRATION\_507

# Wheel Torques and Wheel Pressures

Tolerance (Pressure) =  $\pm 3$  psi

Tolerance (Torques) =  $\pm 15$  ft/lbs

7/8" Socket & 15/16" Socket

3310-40					
Right Wing Outer Tire	11L x 15FI-6 ply	45 psi		160 ft/lbs	
Right Wing Inner Tire	11L x 15FI-6 ply	45 psi		160 ft/lbs	
Right wing rear tire	11L x 15FI-6 ply	45 psi		160 ft/lbs	
MF Right Outer Tire	11L X 15 12ply	90psi		160 ft/lbs	
MF Right Inner Tire	11L X 15 12ply	90psi		160 ft/lbs	
MF Left Inner Tire	11L X 15 12ply	90psi		160 ft/lbs	
MF Left Outer Tire	11L X 15 12ply	90psi		160 ft/lbs	
Left Wing Inner Tire	11L x 15FI-6 ply	45 psi		160 ft/lbs	
Left Wing Outer Tire	11L x 15FI-6 ply	45 psi		160 ft/lbs	
Left wing rear tire	11L x 15FI-6 ply	45 psi		160 ft/lbs	
Left Outer Transport	11L x 15FI-6 ply	45 psi		160 ft/lbs	
Left Inner Transport	11L x 15FI-6 ply	45 psi		160 ft/lbs	
Right Inner Transport	11L x 15FI-6 ply	45 psi		160 ft/lbs	
Right Outer Transport	11L x 15FI-6 ply	45 psi		160 ft/lbs	
3310-48					
Right OW Outer Tire	11L x 15FI-6 ply	45 psi		160 ft/lbs	
Right OW Inner Tire	11L x 15FI-6 ply	45 psi		160 ft/lbs	
Right OW Rear Tire	11L x 15FI-6 ply	45 psi		160 ft/lbs	
Right IW Outer Tire	11L x 15FI-6 ply	45 psi		160 ft/lbs	
Right IW Inner Tire	11L x 15FI-6 ply	45 psi		160 ft/lbs	
Right IW Rear Tire	11L x 15FI-6 ply	45 psi		160 ft/lbs	
MF Right Outer Tire	11L X 15 12ply	90psi		160 ft/lbs	
MF Right Inner Tire	11L X 15 12ply	90psi		160 ft/lbs	
MF Left Inner Tire	11L X 15 12ply	90psi		160 ft/lbs	
MF Left Outer Tire	11L X 15 12ply	90psi		160 ft/lbs	
Left IW Inner Tire	11L x 15FI-6 ply	45 psi		160 ft/lbs	
Left IW Outer Tire	11L x 15FI-6 ply	45 psi		160 ft/lbs	
Right IW Rear Tire	11L x 15FI-6 ply	45 psi		160 ft/lbs	
Left OW Inner Tire	9.5 x 15FI-6 ply	45 psi		160 ft/lbs	
Left OW Outer Tire	9.5 x 15FI-6 ply	45 psi		160 ft/lbs	
Right OW Rear Tire	11L x 15FI-6 ply	45 psi		160 ft/lbs	
Left Outer Transport	11L x 15FI-6 ply	45 psi		160 ft/lbs	
Left Inner Transport	11L x 15FI-6 ply	45 psi		160 ft/lbs	
Right Inner Transport	11L x 15FI-6 ply	45 psi		160 ft/lbs	
Right Outer Transport	11L x 15FI-6 ply	45 psi		160 ft/lbs	

**NOTE: Record Tire pressures in allotted space**

Suggested Completion Time = 20 min.

Signature: \_\_\_\_\_

Actual Time \_\_\_\_\_

3310-55				
11L x 15FI-6 ply	45 psi		160 ft/lbs	
11L x 15FI-6 ply	45 psi		160 ft/lbs	
11L x 15FI-6 ply	45 psi		160 ft/lbs	
11L x 15FI-6 ply	45 psi		160 ft/lbs	
11L x 15FI-6 ply	45 psi		160 ft/lbs	
11L x 15FI-6 ply	45 psi		160 ft/lbs	
12.5 x 15FI-12 ply	90 psi		160 ft/lbs	
12.5 x 15FI-12 ply	90 psi		160 ft/lbs	
12.5 x 15FI-12 ply	90 psi		160 ft/lbs	
12.5 x 15FI-12 ply	90 psi		160 ft/lbs	
11L x 15FI-6 ply	45 psi		160 ft/lbs	
11L x 15FI-6 ply	45 psi		160 ft/lbs	
11L x 15FI-6 ply	45 psi		160 ft/lbs	
9.5 x 15FI-6 ply	45 psi		160 ft/lbs	
9.5 x 15FI-6 ply	45 psi		160 ft/lbs	
11L x 15FI-6 ply	45 psi		160 ft/lbs	
11 x 15FI-8 ply	60 psi		160 ft/lbs	
11 x 15FI-8 ply	60 psi		160 ft/lbs	
11 x 15FI-8 ply	60 psi		160 ft/lbs	
11 x 15FI-8 ply	60 psi		160 ft/lbs	

Suggested Completion Time = 20 min.

Signature: \_\_\_\_\_

Actual Time \_\_\_\_\_

## AIR KITS & GRANULAR KITS

<b>Primary Stand Check</b>	
	<b>CHECK OFF</b>
Ensure that the Quick Coupler can be easily removed by hand	<input type="checkbox"/>
Over center latches installed correctly, move freely, lock pin fits	<input type="checkbox"/>
Left side primary manifold feeds shanks not MRB's (if so equipped)	<input type="checkbox"/>
Hose clamps are tightened on Black Hose (Primary stands)	<input type="checkbox"/>

<b>Secondary Stands Check</b>	
Hose clamps are tightened on Black Hose (Secondary stands)	<input type="checkbox"/>
All muffler clamps have been tightened evenly	<input type="checkbox"/>
Tertiary hoses are not touching any steel hydraulic lines (unless seedboots are not installed)	<input type="checkbox"/>
Minimal uphill run in tertiary hoses (MRB's are Traditional exception to the rule)	<input type="checkbox"/>
Tertiary hoses for M.R.B.s have been hose clamped onto the seedboot	<input type="checkbox"/>
Tertiary hoses are fully seated in secondary manifold( <b>Check 5</b> )	<input type="checkbox"/>
All hose clamps are tight on poly manifolds	<input type="checkbox"/>
Seedboots are mounted straight on the shank (after air hoses have been installed)	<input type="checkbox"/>

<b>Blockage Monitors</b>	
For units with Blockage Modules, ensure that the optical sensor is mounted on the longest hose.	<input type="checkbox"/>
Module Boxes are properly labelled	<input type="checkbox"/>
Ensure sensor wires are not pinched off anywhere (under Module Box covers)	<input type="checkbox"/>
Sensors wires are <b>not</b> installed by Quick Inspection Manifold handles	<input type="checkbox"/>
Ensure Blockage Monitors functions and is tested	<input type="checkbox"/>

Suggested Completion Time = 20 min.

Signature: \_\_\_\_\_

Actual Time \_\_\_\_\_

# Castors and Hitch

<b>CASTORS</b>	<i>check</i>
Tires on castor wheels are not towed in or out but are riding straight	
Walking castor wheels have short offset to the rear of the machine	
Walking castors have the leading tire assembled towards the inside of the unit	
All castors are greased	
All bolts on castor assemblies are tight	
All Dustcaps are dent free (max dent is <b>1/8"</b> ).	

<b>HITCH</b>	<i>check</i>
60,000 lb safety chain has been properly attached (40' - 55' units)	
80,000 lb safety chain has been properly attached (65' & above units)	
All adjustment wrenches are in place	

Suggested Completion Time = 10 min.

Signature: \_\_\_\_\_

Actual Time \_\_\_\_\_



## FINAL CHECK OFF

<b>Various</b>	<b>CHECK</b>
Any oil, dirt, footprints, etc on unit is cleaned up	
Wing pins are tightened	
Winglift cylinder bolts are tightened	
No excess gap between castor pivot axle wear plates (.060" max)[approx. thickness of a quarter]	
Air kit hoses do not kink, when unit is in transport position	
Primary manifolds, elbows and secondary hose do not interfere with trips or packers when unit is in transport position.	
Ensure All MRB 's are fully raised to ensure no interference.	
Hitch jack rotates up and down easily - doesn't bind	
All paint damage repaired	
Ensure wrench set is installed for banders & mounted on the LIW frame	

Suggested Completion Time = 30 min.

Signature: \_\_\_\_\_

\_\_\_\_\_  
Actual Time