



SB069-2024

To: All USA Bourgault Dealers
Attn: Dealer Principals, Sales Managers & Sales Representatives

April 15, 2024

From: Colin Rush

Subject: New Product Release - XR871 & XR851 eXtended Range Harrows

BOURGAULT INTRODUCES THE NEW XR871™ EXTENDED RANGE HARROWS & XR851™ EXTENDED RANGE HEAVY HARROWS



Bourgault Industries is proud to announce the release of the new and improved XR8 Series Harrows. This series is built on Bourgault's extensive history of harrow development, with an all-new frame and running gear design to provide working widths up to 110' - yes, the largest 7-bar harrow on the market!

This new series features industry leading size & strength:

- Available in 90' and 110' working widths,
- The booms have been upsized to 12"x12"x1/4" wall tubing, representing a 70% strength increase,
- The hitch is longer and stronger with positive hitch weight and capability to hold up to 10,000 lb granular tank,
- Larger 500/60R22.5 radial tires all-around,
- Solid tow arms with larger pins and spring-loaded latches, reducing the number of hydraulic circuits down to 3,
- Larger Adjustable DownForce™ circuit hydraulic lines & hoses for faster section response time,
- Fully independent sections with 26" of vertical travel to ensure consistent performance across the entire width.

THE XR8 SERIES CONSISTS OF TWO MODELS:



The **XR871** eXtended Range Harrow is a 7 row design with 1/2"x22" MAX LIFE carbide infused tines.



The **XR851** eXtended Range Heavy Harrow is a 5 row design with 5/8"x26" carbide tines.





Both models are available in 90' and 110' sizes and come with standard carbide tines and the in-cab Adjustable Down- Force System. The ADF™ feature is unique in that it: is constant regardless of contour position, is isolated from other adjustments, is easily adjustable from the cab, and can instantly be placed into float at the headlands to prevent over harrowing of headlands and the bunching of straw. It also includes the patented up-force control to remove weight from the sections in tough conditions including heavy pulse and cereal straw.

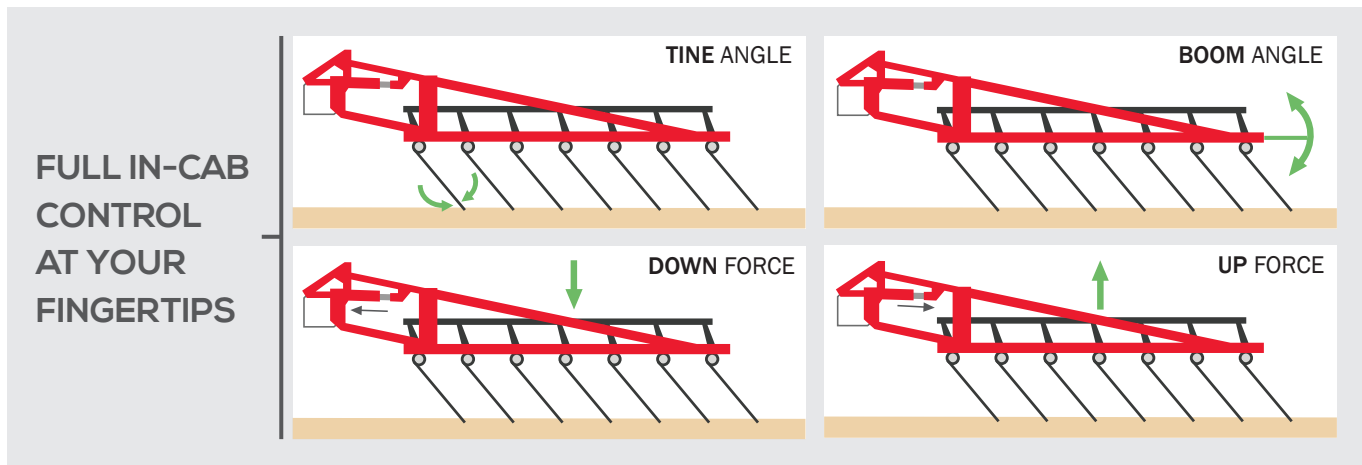

“Since its release in 2017, the Adjustable DownForce System has made the XR harrows the industry leader for performance and ease of setting with in-cab control of all functions.” stated Devin Lung, Product Development Leader - Current Products for Bourgault.

“The new XR8 Series incorporates many improvements to the frame, hitch, and running gear that enable it to perform reliably up to 110' width, while accommodating a large granular tank. We have also improved the response time of the Adjustable DownForce System to ensure each individual harrow section has constant down or up force for a uniform field finish even in extreme contours.”

Easily configurable as 90' or 110'

The XR8 units come from the factory fully-assembled as 90' machines with available 110' extension kits. The 10' boom extensions simply bolt onto the ends of the 90' booms. This adds flexibility for dealer stock to easily sell units as either 90' or 110'.

Machines are also retrofit-able to convert between the sizes as well.

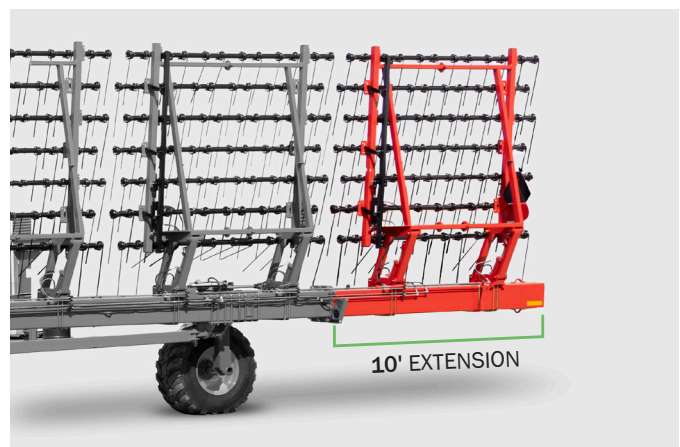



When ordered at 110', a pre-assembled extension kit will ship with the 90' unit that is quickly and easily added at the dealership when required. For towed units, the extension kit is conveniently mounted on the hitch for transport. For hauled units, the extension kit will require an additional truck.

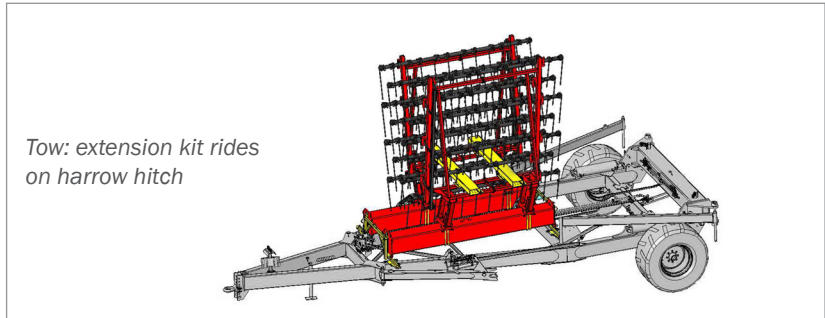

The XR871 and XR851 are available for fall 2024 use. The sales program will be released on April 17th with full details.

Sincerely,

A handwritten signature in black ink that reads "Colin Rush".

Colin Rush

NORTH AMERICAN SALES & MARKETING LEADER